

Mamiya Universal

BLACK



INSTRUCTIONS

Contents

Special Pointers for Using Mamiya Universal	2	Loading Roll Film	21
Main Features	3	Photographing	22
Specifications	4	Roll Film Holder Model K	23
Description of Parts	5	Prior to Loading Roll Film Holder..	23
Assembling	7	Loading Roll Film	23
Attaching the Lens..	7	Focusing Hood	24
Pulling Out the Lens from its Retracted Position..	7	Polaroid Land Pack Film Holder	25
Attaching the Hand Grip	8	Short Course on Photography	25
Stabilizing Plate	8	Accessories for Polaroid Land Pack Film Holder	26
Attaching the Back	9	Focusing Hood Model P	26
M Adapter	9	Optical Viewfinder Model P	26
G Adapter..	10	Format Gauge	26
Polaroid Land Camera Back..	10	Focusing Screen Holder	27
Operating the Viewfinder	10	Right-angle and Magnifying Focusing Backs	28
Selecting Brilliant Frame in the Viewfinder	11	Composing the Picture by Ground Glass Focusing Screen for Cut Film	29
Focusing with Coupled Rangefinder..	11	Cut Film/Plate Holder Type J	30
Areas of Viewfinder Field to be Composed	12	Cut Film/Plate Holder Type A	31
When Using Roll Film Holder	12	Extension Rings	32
Distance Range Composed by Brilliant Frame	12	Spacer Set	33
When Using Polaroid Land Pack Film Holder	13	Life-size Photocopying Set	36
Depth of Field Scale and Infrared Photography	15	Tetraphoto Adapter	37
Depth of Field Scale	15	Accessories for the Viewfinder	38
Infrared Photography	15	Grip and Tripod Adapter	39
Shutter Operation	16	Cases	41
Press Focus Operation	16		
Using Flash	17		
ACCESSORIES	18		
Acceptable Photosensitive Material and Actual Picture Size	19		
Roll Film Holder (6 x 9, 6 x 7)	20		
Description of Parts	20		
Prior to Loading Roll Film	21		

Special Pointers for Using Mamiya Universal

Refer to the following pages for further details.

- 1.** The 100 mm f/3.5 lens is a retracting type. When the lens has been retracted, focusing cannot be effected although the two images on the rangefinder coincide.

Page 7

- 4.** When taking photographs with the vertical format camera position, on a tripod, use a tripod adapter on the hand grip socket for vertical format photography.

Page 40

- 2.** Be sure to cock the shutter before keeping the shutter open with the press focus lever. Disengage the lever lock button and turn the lever in the same direction as the shutter cock; then the shutter will remain open. By pushing the lever back to its original position, the shutter will close.

Page 16

- 5.** When using the roll film holder for Mamiya RB or the various film holders and adapters for the 2 1/4 x 3 1/4 Graflok® back, made by GRAFLEX®, Inc., use the G adapter instead of the M adapter.

Page 10

- 3.** When framing a 6x9 or 6x7 composition with the finders brilliant frame, compose it within the inner edges of the frame width for short distances; use the outer edges as a guide for long distances.

Page 12

Main Features

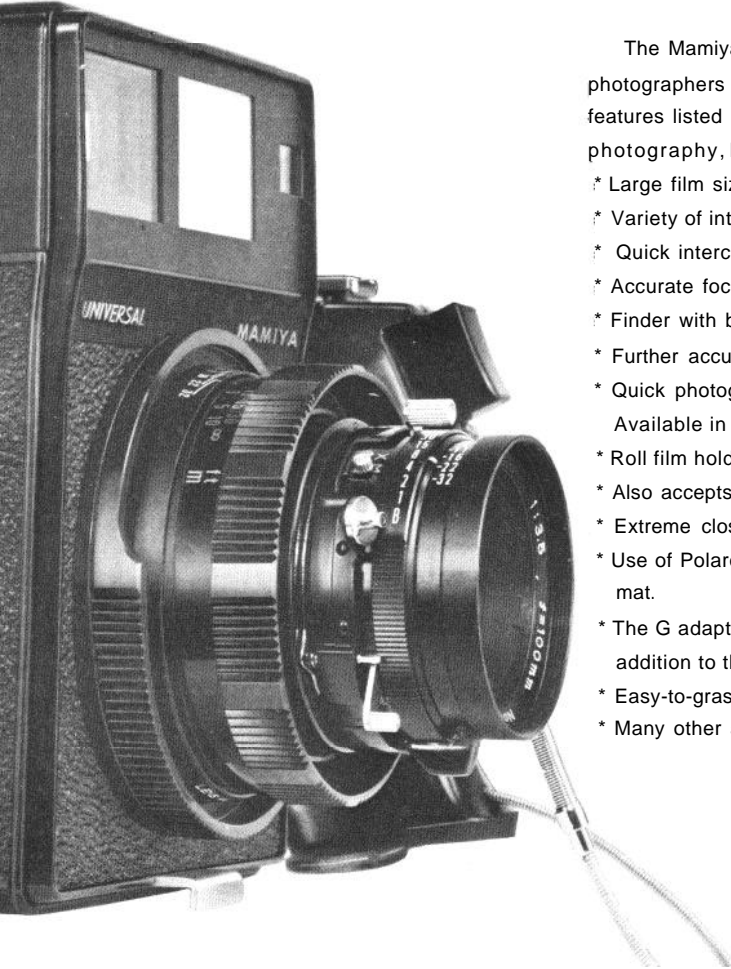

The Mamiya Universal, the same unique breed as the Mamiya Press used by professional photographers both at home and abroad, is a large 6 x 9 film format camera with the functional features listed below. It offers the distinct advantage of its large film size not only for general photography, but also for news photography, commercial work, and scientific application.

- * Large film size presents sharp, fine rendition of every detail.
- * Variety of interchangeable lenses ranging from 50 mm wide angle to 250 mm telephoto.
- * Quick interchangeability of lenses with bayonet ring mounting.
- * Accurate focusing through coupled rangefinder.
- * Finder with bright, easy-to-see brilliant frame, featuring automatic parallax compensation.
- * Further accurate focusing through ground glass focusing screen possible.
- * Quick photography with roll film holder (lever winding system).
Available in 6 x 9 and 6 x 7 format for both 120 and 220 films.
- * Roll film holder K enables photography in 6 x 9, 6 x 6, or 6 x 4.5 format.
- * Also accepts dry plates and cut films, providing for single shots with these films.
- * Extreme close-up photography through using spacer set and/or extension rings.
- * Use of Polaroid Land pack film holder offers instant photographic prints in 3¼ x 4¼ inch format.
- * The G adapter enables using the roll film holder and various film holders for Mamiya RB, in addition to the film holders of 2¼ x 3¼ Graflok back made by Graflex, Inc.
- * Easy-to-grasp hand grip with cable release for added versatility.
- * Many other accessories available for any type of photography.

Specifications

Type	: Interchangeable lens type 6 x 9 format camera	Back mount	: Interchangeable back, three types (M adapter, G adapter, and Polaroid Land camera back) can be attached.
Picture size	: Photography with 6 x 9, 6 x 7, and 6 x 4.5 formats by using various holders. When using the POLAROID LAND pack film holder, actual picture size is 73 x 95 mm.	Grip	: Removable hand grip with cable release.
Lens mount	: Breech lock bayonet mount type.	Others	: Flashgun mounting socket, accessory shoe, camera body stabilizing plate, and tripod socket are provided.
Shutter	: SEIKO #0 shutter Shutter speed B, 1 -1/500 second Flash synchronization, M and X selecting type. With press focus device (shutter blade arresting)	Physical dimensions	: (Camera body, with 100 mm f/3.5 lens) Height: 6 19/32 in. (167 mm) Width: 4 25/32 in. (121 mm) without hand grip Depth: 4 1/2 in. (114 mm) lens in retracted position, distance scale at infinity (Camera body with 127mm f/4.7 lens) Height: 6 19/32 in. (167 mm) Width: 4 25/32 in. (121 mm) without hand grip Depth: 6 in. (152 mm) Weight: Camera body: 2 lbs. 1 1/2oz. (950 gr.) 100 mm f/3.5 lens: 1 lb. 1 oz. (480 gr.) 127 mm f/4.7 lens: 1 lb. 9/16 oz. (470 gr.) Hand grip: 10 9/16 oz. (300 gr.)
Standard lens	: 100 mm f/3.5 retracting type, minimum aperture f/32, with lens hood. 127 mm f/4.7, minimum aperture f/64, with lens hood.		
Rangefinder	: Reversed Galileian telescope, couples double-image coincidence type, instant coupling to selected lens.		
Viewfinder	: Adjustable brilliant frame fields for 100 mm, 150 mm, and 250 mm lenses; 6 x 9 and 6 x 7 formats; Automatic parallax compensation. Use exclusive optical viewfinders for 50 mm and 75 mm lenses. When photographing through the Polaroid Land film pack size, use the optical viewfinder model P for 75, 100, and 127 mm lenses.		

Description of Parts

1. Accessory shoe
2. Strap eyelet
3. Flashgun mount
4. Flashgun mounting socket
5. Back locking slide
- 5' Lock button
6. Bayonet ring
7. Stabilizing plate
8. Hand grip socket
9. Rangefinder coupling pin
10. Lens coupling mark
11. Cable release holder
12. Hand grip lock ring
13. Shutter release trigger
14. Hand grip
15. Cable release
16. Depth of field scale
17. Distance scale
18. Focusing ring
19. Shutter cocking lever



- 20. M-X selector
- 21. Shutter speed dial
- 22. Synchroflash terminal
- 23. Shutter release lever
- 24. Aperture control lever
- 25. Cable release socket
- 26. Press focus lever
- 26' Press focus lever lock button
- 27. Indicator window for viewfinder field frame
- 28. Slide button for viewfinder field frame selection
- 29. Eyecup
- 30. Eyepiece
- 31. Tripod socket
- 32. M adapter
- 33. Locking knob
- 34. G adapter
- 35. Locking slide

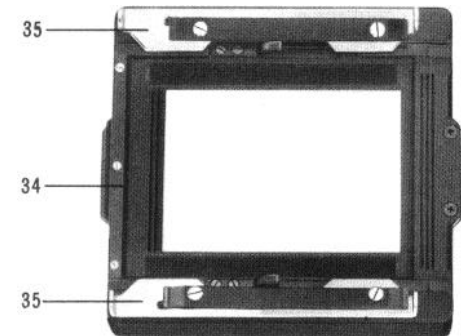
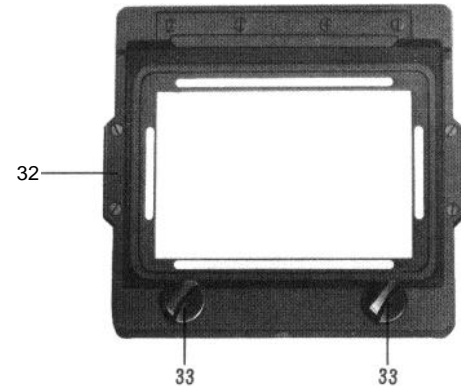
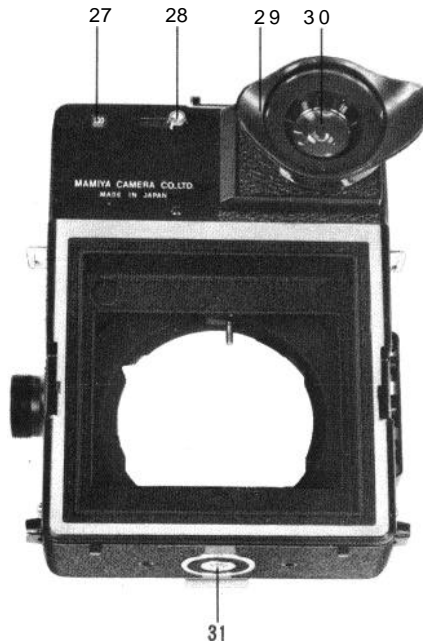

Assembling

Attaching the Lens

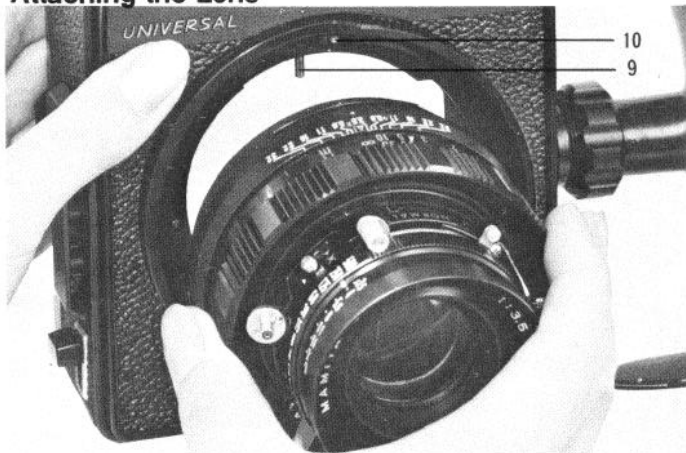

By rotating the bayonet ring counter clockwise until it stops, the red dot of the lens coupling mark on the bayonet ring comes to the top, and the dust cap on the front of the camera body can be removed. At this position of the bayonet ring, insert the lens, matching the red mark on the lens to the red mark on the bayonet ring. Then turn the bayonet ring clockwise, locking the lens in place.

Detaching the lens is done in a reverse order to that described above.

PRECAUTION !

Do not touch the pin (9) on the camera body used to couple the lens to the rangefinder.

If the lens is changed while a loaded film holder is attached to the camera, be sure to insert a dark slide into the holder.

Pulling Out the Lens from its Retracted Position

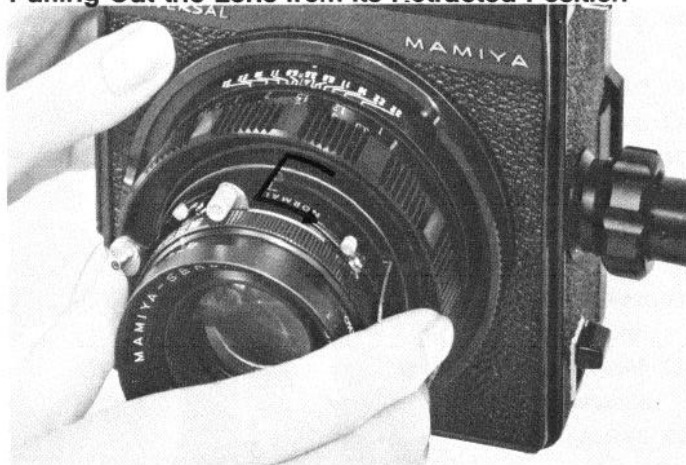

When using the 100mm f/3.5 standard lens, the lens-shutter assembly must be pulled out from its retracted position before taking general photographs. Grip the lens-shutter assembly firmly, turn it slightly counterclockwise, and pull it out; then, turn it clockwise (in the arrow direction) and secure it in place.

If the lens-shutter assembly is left in its retracted position, the coupled rangefinder will not function even when the two images coincide and form a single image.

Although the lens is not used for normal photography with the lens-shutter assembly in its retracted position, the lens is designed to allow its lens-shutter assembly to remain retracted so that it can be used even when extension rings are used.

Also lens retraction is necessary, when using this lens with another camera whose back mount can be extended, when taking a picture with the back mount tilted.

Attaching the Hand Grip

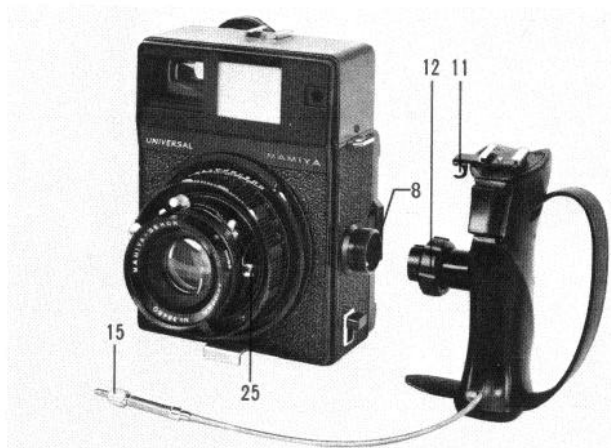

To attach the hand grip, insert the hand grip into the grip socket (8) of the camera body, and firmly turn the hand grip lock ring (12).

Screw the end of the cable release (15) extending from the hand grip into the release socket (25) of the lens-shutter assembly.

While dismounting a lens, hang the cable release on the cable release holder (11).

Stabilizing Plate

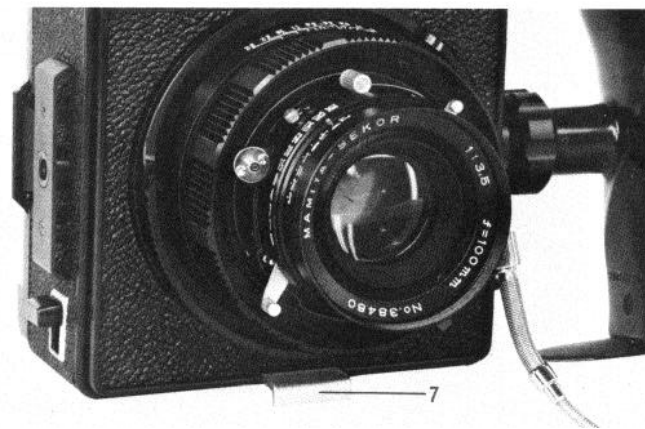

Pull out the stabilizing plate (7) on the bottom of the camera body when resting the camera on a desk, table, or other surface.

Assembling

Attaching to Back

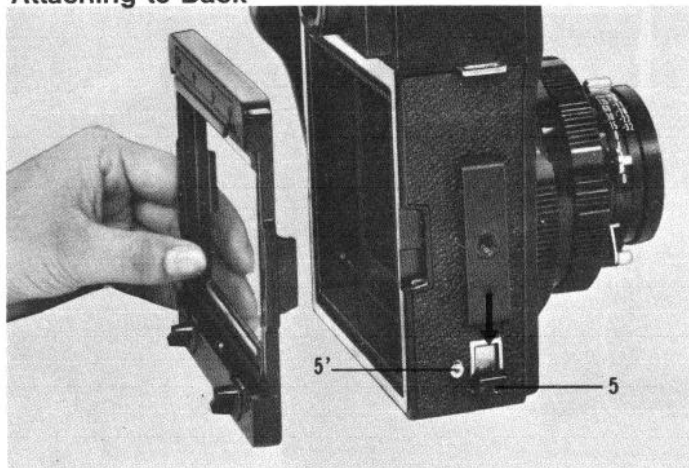

Before attaching the back, confirm that both side locking slides (5) are kept at their lowest position. If not, push down the locking slide while pushing in the lock button (5').

Align the red point on the M adapter, G adapter, or Polaroid Land camera back (Polaroid Land pack film holder and focusing hood model P) with the red point on the camera body, inserting both sides of the protruded portions to the indented portions on the camera body.

Securely push up the locking slide on both sides. While pushing up the slide, the lock button will spring out automatically. The lock button functions to prevent the back from being detached unexpectedly from the camera body.

Secure both sides of the back by using the locking slides (5). Do not raise the camera by holding the back in a condition that only one side is secured.

To remove the back, depress both side locking slides (5) while the lock buttons (5') are pushed in.

M Adapter

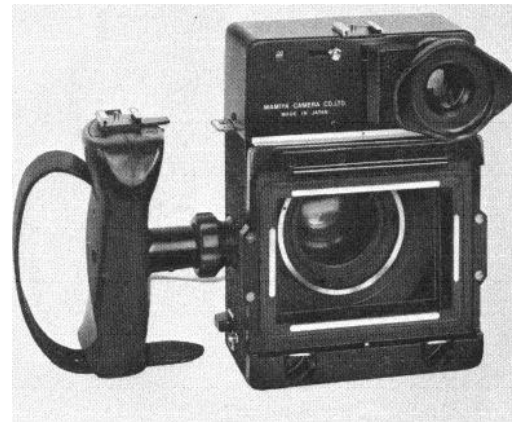

When installing the M adapter on the camera back, the roll film holder for Mamiya Press, focusing screen holder, and so on can be used.

To attach the above-mentioned accessories to the adapter, keep the flattened edges of the two locking knobs of the M adapter parallel with the bottom line of the picture format, insert the top of the holder in the upper groove, and push in the bottom: then rotate the two knobs 90 degrees either to the right or left.

G Adapter

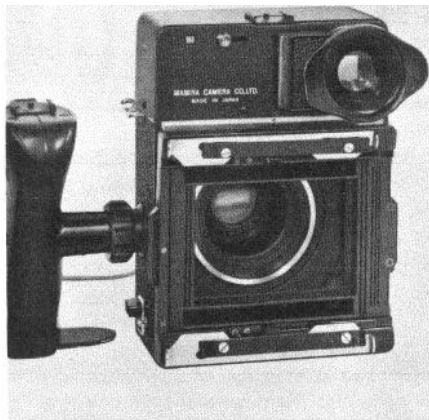

When the G adapter is attached instead of the M adapter, the roll film holder for Mamiya RB can be used. Furthermore, the roll film holder and the focusing panel made by GRAFLEX, Inc., and accessories for the GRAFLOK back can be employed.

Polaroid® Land Camera Back

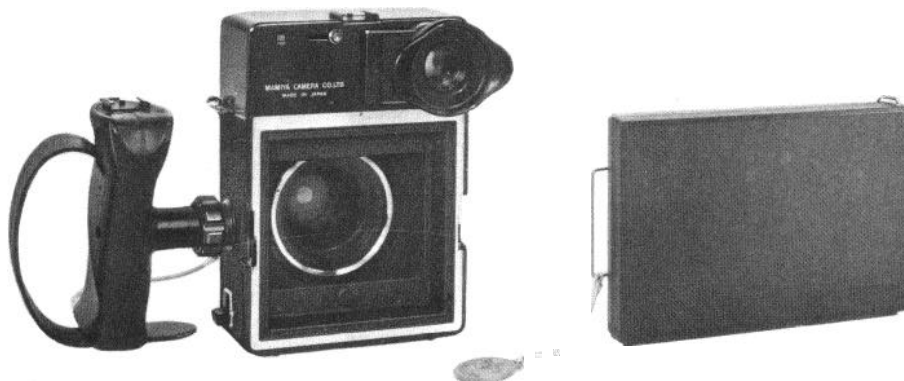

Remove the camera back adapter and attach the Polaroid Land camera back directly to the camera body. The Polaroid Land pack film holder and the focusing hood model P are available.

With the Polaroid Land pack film holder, use a Polaroid a-exposure, 3 1/4 x 4 1/4 inch Land film pack. For color photography, use Polaroid Polacolor® film type 108 or 668, for black-and-white photography, use Polaroid Land film type 107, 665 or 667

By attaching the focusing hood model P, direct focusing through the ground glass focusing screen of 3 1/4 x 4 1/4 inch format (ef-

fective picture size of 2 7/8 x 3 3/4 inch, 73mm x 95mm) becomes possible. On the ground glass focusing screen are 6 x 9 and 6 x 7 format indicating lines.

NOTE :

The back attaching system used on this camera is exclusive with Mamiya; thus, do not attempt to use other Polaroid Land camera backs.

Operating the Viewfinder

Selecting Brilliant Frame in the Viewfinder

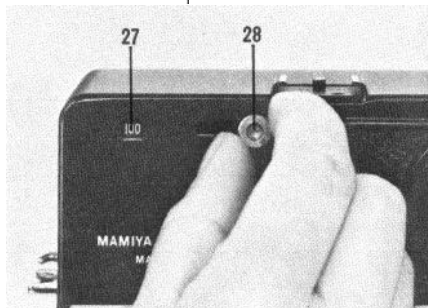

The viewfinder field frame, indicating the field for 6 x 9 and 6 x 7 formats, is adjustable for 100mm, 150mm and 250mm focal length lenses. By sliding over the slide button (28), adjust the number in the indicator window (27) to match the focal length of the using lens.

When using the 50mm or 75mm lens, attach the exclusive optical viewfinder of each lens to the accessory shoe on the camera body.

Focusing with Coupled Rangefinder



Within the small circle in the center of the viewfinder field two images of the subject are visible. Turn the focusing ring so that these two images coincide.

When focusing, coincide the double images at the center of the circle. Looking through the center of the eyepiece is also a key point in accurate focusing. When turning the focusing ring of the lens barrel, be careful not to turn the bayonet ring of the camera body.

When the lens-shutter assembly is in a retracted position, or when extension rings are used, the rangefinder will not function even though the double images coincide.

Parallax

Brilliant frames in the viewfinder for 100 mm, 150mm and 250mm lenses are coupled with the rangefinder to automatically correct parallax.

Areas of Viewfinder Field to be Composed

When using Roll Film Holder

When composing the 6 x 9 or 6 x 7 format with the viewfinder frame, employ inside edges of the frame for subjects at close distance; use the outer edges of the frame for subjects further away.

Distance Range Composed by Brilliant Frame

Focal length of lens	For close ranges, use inside edges of frame	For distances further away, use outside edges of frame
100mm f/2.8 f/3.5	3.5ft to approx. 6ft (1m) (2m)	approx. 6ft. to infinity (2m)
150mm f/5.6	6ft. to approx. 9ft. (2m) (3m)	approx. 9ft. to infinity (3m)
250mm f/5	—————	approx. 12ft. to infinity (4m)

The 250mm f/5 lens interlocks with the range-finder from distances of 20 ft (7m) to ∞ (infinity).

When photographing with the 6 x 6 format or 6 x 4.5 format by employing the roll film holder model K, use the attached finder mask. See page 24 for details.

6 x 9

For close range

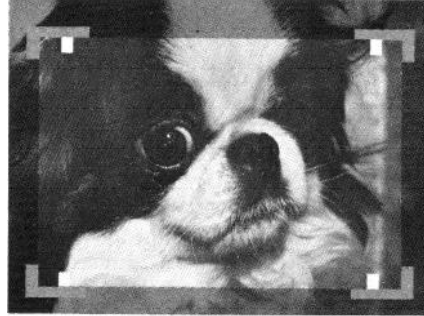

6 x 7

For close range



For distances further away

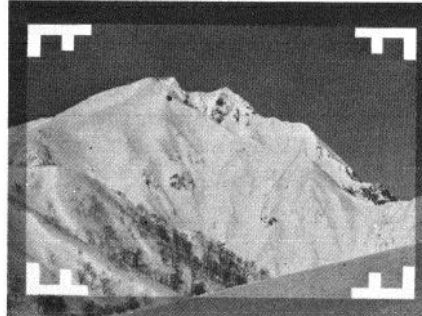

For distances further away

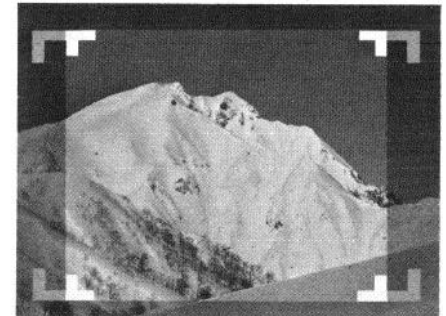

Areas of Viewfinder Field to be Composed (cont.)

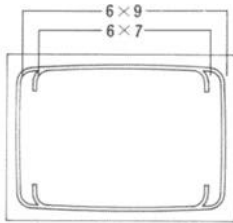

50mm Lens Attach the optical viewfinder for 50mm lens on the accessory shoe. To correct parallax, turn the knob at the back of the viewfinder and select the same distance scale shown on the dial as the focused distance to subject.

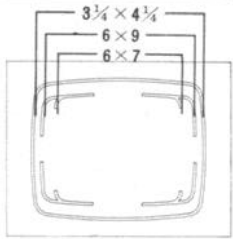

75mm Lens Attach the optical viewfinder for 75mm lens to the accessory shoe. To correct parallax, turn the knob at the back of the viewfinder and select the same distance scale shown on the dial as the focused distance to subject. (The brilliant frame of 3 1/4 x 4 1/4 inch format indicates the field of view when photographing with the Polaroid Land pack film holder).

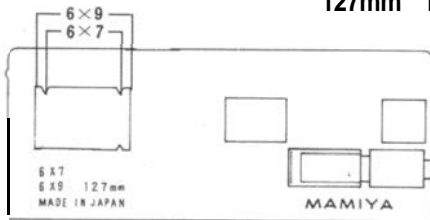

127mm Lens Attach a finder mask to the viewfinder window of the camera body. For correcting parallax, select the brilliant frame of the viewfinder for 250mm lens, moving your eye about until the brilliant frame is centered in the viewfinder field.

When Using Polaroid® Land Pack Deciding the Field Composition

Since the Polaroid film pack photographs a wider area than does the viewfinder field frame of the 6 x 9 cm format, compensate the field composition in the following manner, depending on the focal length of the lens to be used. For accurate field composition, use the focusing hood model P. Also, the optical viewfinder model P for 75mm, 100mm and 127mm lenses is available to ensure accurate field of view.

The 75mm and 127mm focal length lenses are designed to cover the entire picture area of the Polaroid film pack (3 1/4 x 4 1/4 inch format). However, since other ordinary Mamiya Press lenses are designed for the 6 x 9 cm format, if these lenses are used with the Polaroid film pack, the four corners of the format may be slightly darkened.

Film Holder

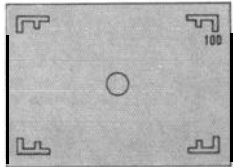

With the 100 mm lens :
Use the viewfinder entire area. In this case, the actual picture area covers a slightly wider field.

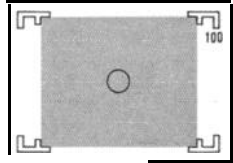

With the 127mm lens:
By observing the camera viewfinder, determine the field of view by using the 6 x 7 format brilliant frame for 100 mm lens as a guide.

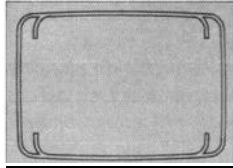

With the 50mm lens:
Attach the optical viewfinder for 50 mm lens on the accessory shoe and observe the viewfinder entire area.

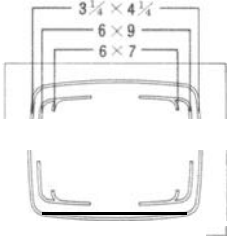

With the 75mm lens:
Use the brilliant frame for 3/4 x 4/4 format in the optical viewfinder for 75mm lens.

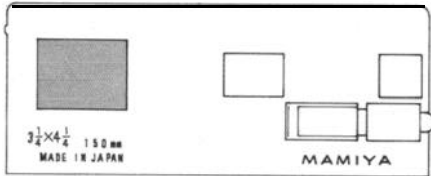

With the 150mm lens:
Determine the field of view by covering the viewfinder mask for 3/4 x 4/4 format on the camera finder window,

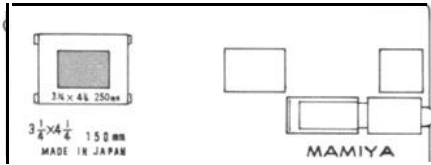

With the 250mm lens:
Determine the field of view by inserting the mask for 250mm lens in the finder mask for 150mm lens.

Depth of Field Scale and Infrared Photography

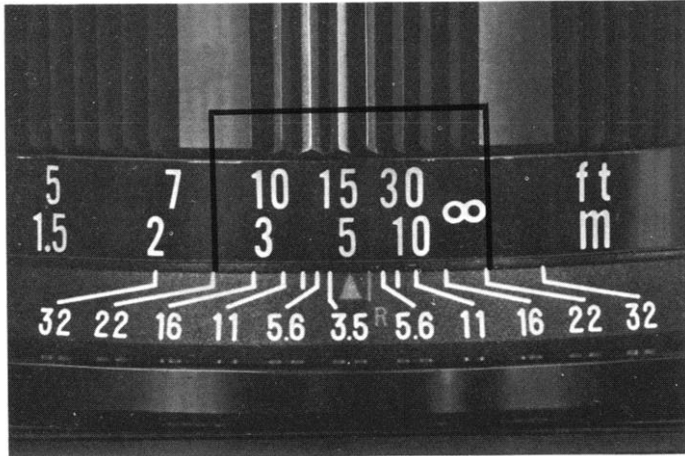

Depth of Field Scale

Standard f-stop marks, indicating the depth of field for the aperture used, are located on both sides of the triangle mark (▲) on the depth of field ring. This indicates that subjects within a definite area will be in sharp focus on the photograph. For example, when focusing on a subject 15 feet (5 meters) away with a 100 mm standard lens at f/22, everything between 8 feet (2.5 meters) and infinity is in focus.

Infrared Photography

When photographing with infrared film, the distance scale obtained by focusing with the rangefinder must be shifted by rotating the focusing ring slightly until the focused point on the distance scale is changed to align with the small red "R" on the depth of field ring.

Use a red filter when photographing with infrared film.

Shutter Operation

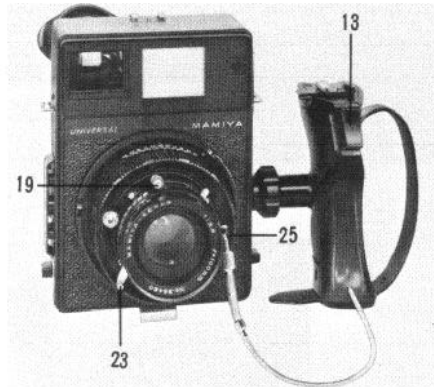

Cock the shutter by moving the shutter cocking lever (19).

Screw the end of the cable release which extends from the hand grip into the cable release socket (25).

To release the shutter, press the shutter release trigger of the hand grip with the left forefinger. Also, the shutter can be released by tripping the shutter release lever (23).

Press Focus Operation

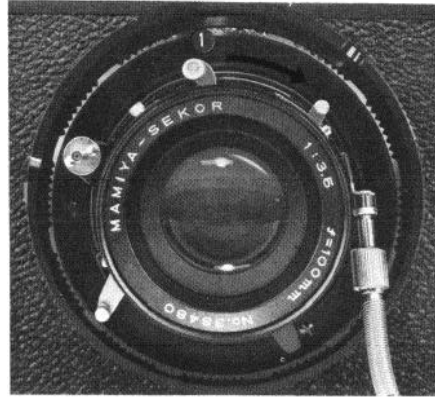

When focusing through the ground glass, keep the shutter open by the following method.

1. Cock the shutter, regardless of the shutter speed setting.
2. Disengage the lock button by thoroughly pushing it to the camera body side and turn the press focus lever in the shutter cock direction; then the shutter will remain open.



By pushing the press focus lever back to its original position, the shutter will close. There is no need to reset the shutter.

PRECAUTION :

Be sure to operate the press focus lever **AFTER** cocking the shutter. While the shutter is kept opened, the shutter cannot be released with the shutter release button.

Applying an excessive force to the release button may cause shutter damage.

When the press focus lever is not used, be sure to engage the lock button to prevent inadvertently moving the lever.

Using Flash

Shaded area of the above table indicates the synchronizing shutter speed.

Move the MX-selector lever to obtain the right terminal.

When the MX-selector is set to M, M-class bulbs synchronize to all shutter speeds.

When the MX-selector is set to X, electronic flash synchronizes to all shutter speeds.

Flash Synchronizing Table

Terminal	Flash bulb	Shutter speed										
		1	$\frac{1}{2}$	$\frac{1}{4}$	$\frac{1}{8}$	$\frac{1}{15}$	$\frac{1}{30}$	$\frac{1}{60}$	$\frac{1}{125}$	$\frac{1}{250}$	$\frac{1}{500}$	
M	M-class											
X	Electronic flash											
	F-class											
	M-class											



Accessories



Acceptable Photosensitive Material and Actual Picture Size

Type of holder	Photosensitive material			Number of exposures
	Type	Nominal size	Actual picture size	
6 X 9 cm roll film holder	Roll film	120	$2\frac{13}{64} \times 3\frac{5}{16}$ in. 56X84mm	8
		220	#	16
6 X 7 cm roll film holder	Roll film	120	$2\frac{13}{64} \times 2\frac{43}{64}$ in. 56 X 68mm	10
		220	#	20
Roll film holder model K (6 X 9, 6 X 6, 6 X 4.5cm)	Roll film	120	$2\frac{13}{64} \times 2\frac{43}{64}$ in. 56 X 84mm	8
			$2\frac{13}{64} \times 2\frac{13}{64}$ in. 56 X 56mm	12
			$1\frac{41}{64} \times 2\frac{13}{64}$ in. 41.5 X 56mm	16
Cut film/plate holder (type J)	Plate	$2\frac{1}{2} \times 3\frac{1}{2}$ in. 6.5 X 9cm	$2\frac{1}{4} \times 3\frac{5}{16}$ in. 57 X 84mm	1
	Cut film	$2\frac{1}{2} \times 3\frac{1}{2}$ in. 6.5 X 9 cm	#	
	Cut film	$4\frac{3}{4} \times 6\frac{1}{2}$ in. size divided into 4 equal parts	$2\frac{1}{4} \times 3\frac{1}{32}$ in. 57 X 77mm	
Cut film/plate holder (type A)	Plate	$2\frac{1}{2} \times 3\frac{1}{2}$ in. 6.5 X 9 cm	$2\frac{1}{4} \times 3\frac{5}{16}$ in. 57 X 84mm	1
	Cut film	$2\frac{1}{4} \times 3\frac{1}{4}$ in.	$2\frac{3}{64} \times 3\frac{5}{64}$ in. 52 X 79mm	
Polaroid Land pack film holder	Polaroid film pack series 100 or 660	$3\frac{1}{4} \times 4$ Kin. (8.3 X 10.8cm)	$2\frac{7}{8} \times 3\frac{3}{4}$ in. 73 X 95mm	8

Roll Film Holder (6 x 9, 6 x 7)

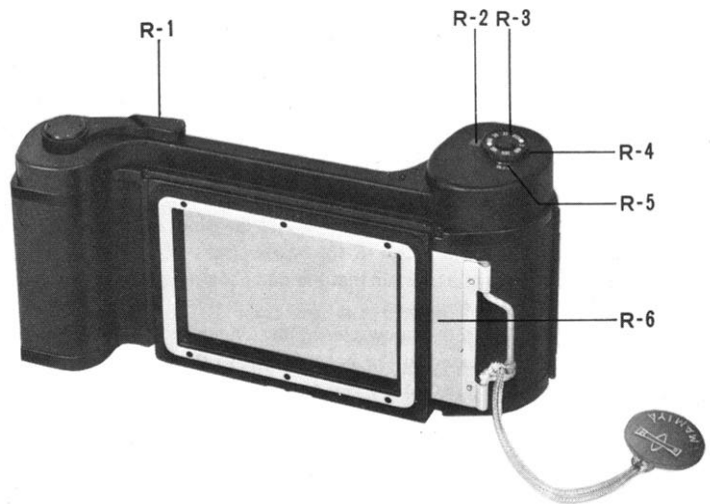

There are two types of roll film holders— one for 6×9cm and the other for 6×7cm formats. Both types accept 120 and 220 roll films.

Holder Type	Films	Number of exposure
6 × 9	120	8
	220	16
6 × 7	120	10
	220	20

Description of Parts

- R - 1 Film Advance Lever
- R - 2 Film Counter Window
- R - 3 Film Sensitivity Reminder Dial
- R - 4 Counter Change-over Knob
- R - 5 Film indicator Window
- R - 6 Dark Slide
- R - 7 Film Wind-stop Release Lever
- R - 8 Film Chamber
- R - 9 Back Cover Latch
- R - 10 Spool Change Knob
- R - 11 Start Mark
- R - 12 Take-up Spool Chamber
- R - 13 Plate Catch (Left)
- R - 14 Pressure Plate
- R - 15 Plate Catch (Right)

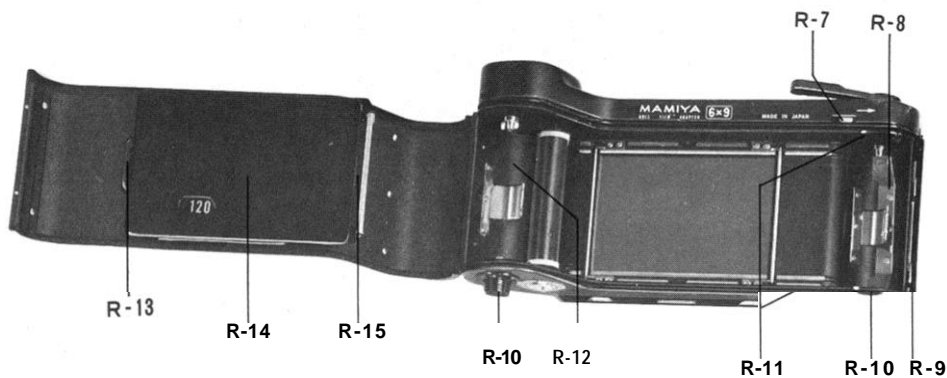

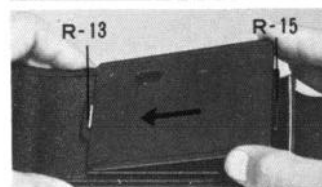
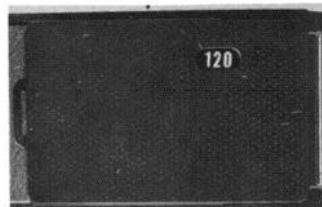
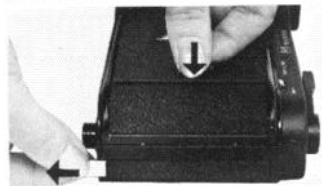
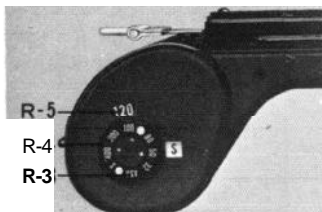

Prior to Loading Roll Film

Set the automatic film wind stop device for the film to be used (120 or 220).

Turn the counter change-over knob (R-4) either to the right or left until the figure appearing in the film indicator window (R-5) corresponds to that of the film to be used (120 or 220).

Open the back cover

By pulling out the back cover latch while pressing the back cover to the holder, the back cover can be opened.

Make sure that the correct side of the pressure plate corresponds to the film used.

One side of the pressure plate (R-14) is for No. 120 roll film and the other side is for No. 220. The figure "120" or "220" is indicated on the window of the pressure plate.

Reverse the pressure plate if it does not match the film

Removing the Pressure Plate:

Remove the plate by pushing its right side to the left, pulling it out from the plate catch (R-15).

Reattaching the plate :

While aligning the upper and lower edges of the plate with the flange, insert the groove into the plate catch (R-13) on the left, then hook the plate catch (R-15) on the right while pushing it slightly to the left. Always ascertain that the correct side of the pressure plate corresponds to the film used.

Use the convenient film sensitivity reminder dial (R-3) as a memo of film speed in the holder, turning the dial corresponding to the loaded film speed to the red mark.

Loading Roll Film

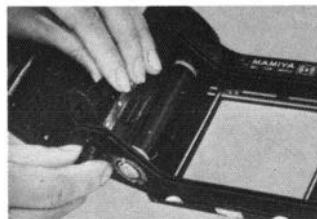

Avoid direct sunlight while loading or unloading film. Do it in the shade.

Pull out the spool change knob (R-10) and place an empty spool into the spool chamber (R-12),

Pull out the other spool change knob (R-10) and place a roll film into the film chamber (R-8).

By turning the spool change knob either to the right or left after pulling it out, the knob will remain projected. By turning back the knob, the knob will snap back to its original retracted position.

The memo clip at the holder back cover can accommodate a film box lid or a blank paper pad for memorandum.

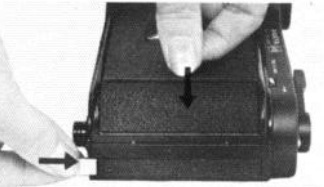
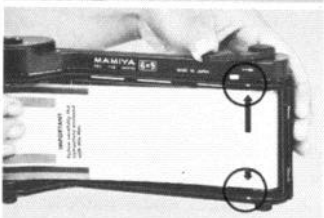

Draw out the end of the leader paper of the film, inserting the tip into the slit of the take-up spool.

If the spool is not in the proper position or the leader paper of the film is not correctly inserted into the take-up spool slit, film winding cannot be operated properly or smoothly.

Wind the film advance lever (R-1) gradually until the start mark on the leader paper aligns with the start marks (R-11) on the holder.

Close the back cover and push in the back cover latch, keeping the back cover pressed to the holder.

When the back cover is closed, the start marks will be slightly separated; however, this implies no bad effect whatsoever.

As the film advance lever is carefully wound, figure "1" appears in the film counter window and the lever stops winding. Even before figure "1" appears in the film counter window, a heavy drag may be felt; however, continue winding until the lever actually stops. Now the first film frame is ready to be exposed

Photographing

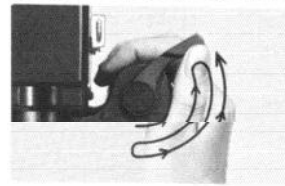
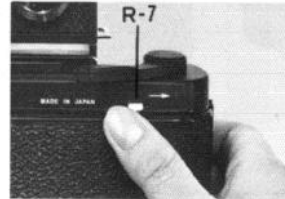

Attach the loaded roll film holder to the camera body.

Pull out the dark slide (R-6); now, start taking photographs,

After each exposure, by moving the film wind-stop release lever (R-7) in the direction of the arrow, the film can be advanced by turning the film advance lever.

Since the film will not advance far enough with only one stroke of the film advance lever, turn the lever until it stops at the second stroke. Winding may be accomplished by moving the lever with several short, definite strokes until the lever stops, although never wind the lever too rapidly.

After all frames have been exposed, move the wind-stop release lever (R-7) once, then continue turning the film advance lever until you feel tension on the advance lever lessen as the leader end of the film slips off the spool, finally turning it freely in the take-up chamber. Now open the back cover and remove the film.

Fully insert the dark slide when the roll film holder is to be detached or when the lens is interchanged before completing a roll of film,

Without a film loaded, turning the film advance lever will not advance the film counter which remains at the start (S) mark. When some other mark is visible in the film counter window, it is your assurance that a film is loaded.

Roll Film Holder Model K

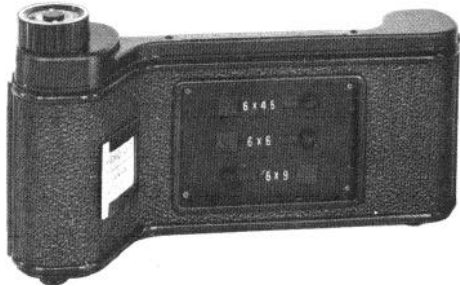

This holder is for taking 6 x 9, 6 x 6 and 6 x 4.5 format pictures with a 120 roll film. The film is advanced by turning the knob. The number of exposures are read on the back of the holder.

The memo clip at the holder back cover can accommodate a film box lid or a blank paper pad for memorandum.

Prior to Loading Roll Film

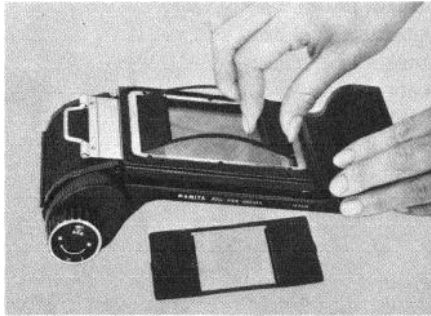

Unless photographing in 6 x 9 format, the viewfinder field as well as the picture format of the holder must be changed.

Installing the Picture Frame

Attach the picture frame for 6 x 6 or 6 x 4.5 format into the holder while a dark slide is inserted in the holder. Insert the picture frame so that the folded portion enters the dark slide side (inner side). Insert the claws on both ends into the grooves of the picture frame of the holder while slightly bending the picture frame lengthwise (as shown in the photo).

Loading Roll Film

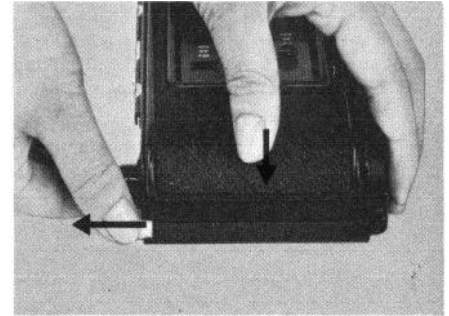

When loading or unloading a film, avoid direct sunlight. Do it in the shade.

By pulling out the back cover latch while pushing the back cover toward the holder, the back cover can be opened.

Pull out the spool change knob and place a roll film in the film chamber.

Pull out the leader paper of the film, insert the edge of the leader paper into the slit of the take-up spool and wind it around the spool once; then close the back cover. When closing the back cover, press the back cover toward the holder, pushing into the back cover latch.

While observing the window for the picture format to be photographed, turn the film advance knob clockwise until figure "1" appears in the window.

Avoid direct sunlight when opening the back window.

Focusing Hood

Attach the holder to the camera body, pull out the dark slide, and start to photograph.

After each exposure, open the back window, and turn the film advance knob until the next figure appears in the window.

When removing the holder from the camera or changing the lens while the film is loaded, **be sure to insert the dark slide.**

Viewfinder Field for Photographing in 6 x 6 or 6 x 4.5 Format.

Attach a finder mask for 100mm lens to the viewfinder window of the camera body (this mask is for 6 x 6 format). For photographing in 6 x 4.5 format, insert the mask for 6 x 4.5 format into the back of the 6 x 6 format mask.

To attach the mask to the camera body, raise the flat spring attached in front of the mask by holding it with the thumb and forefinger, and apply the mask to the top cover front frame and releasing the raised flat spring.

To correct parallax, select the brilliant frame for 250mm lens, moving the eye around while looking into the viewfinder until the brilliant frame is centered in the entire viewfinder field.

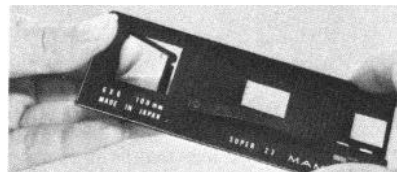
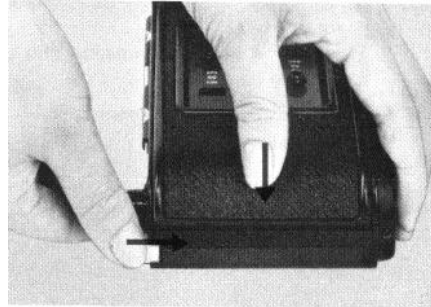

For accurate focusing or for confirming the depth of field, use the focusing hood. A Fresnel lens is used with this focusing hood to make the whole image brighter and easier to focus.

Polaroid® Land Pack Film Holder

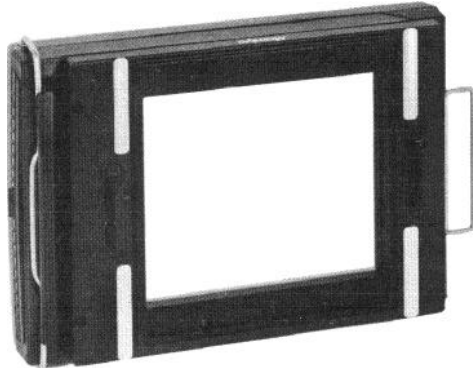

With a Polaroid Land film pack, you can obtain a color print in 60 seconds, and a black-and-white print in 15 seconds.

For color pictures, use Polaroid Polacolor film, Type 108 or 668.

For black and white pictures, use Polaroid Land film Type 107, 665 or 667.

Both color and black-and-white films are eight-exposure film packs.

Actual picture size is 2 7/8 x 3 3/4 inches (73 x 95mm). Install this holder directly on the camera body after removing the M adapter.

“Short Course” on photography

- 1** Install a holder containing film pack on the camera.

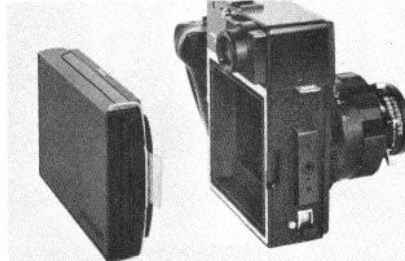

- 2** Pull out the white tab, then a yellow tab pops out and take a picture after pulling out the dark slide.

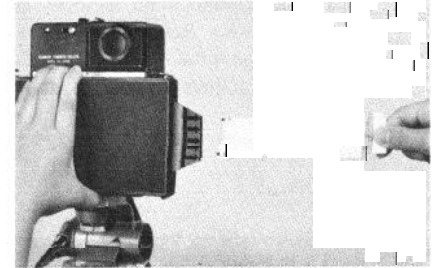

- 3** Pull the yellow tab straight out of the holder and at a constant speed. Development starts from this operation.

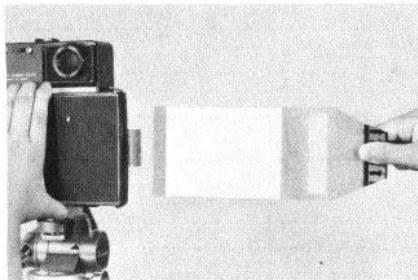

- 4** After the recommended development time, strip off the white paper (the print). The photo will be completed.

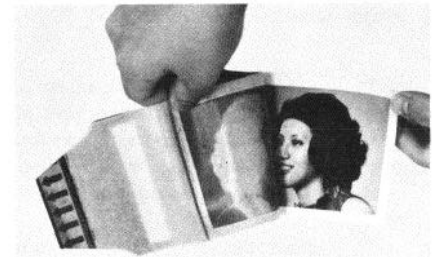

* Further detailed explanation is provided with the purchased holder.

Accessories for Polaroid® Land Pack Film Holder

Focusing Hood Model P



This focusing hood has the same size format as the Polaroid Land film pack. The focusing screen has a Fresnel lens, offering a bright, sharp image on the screen. Use this focusing hood to confirm accurate focus or the actual picture format.

Since this focusing screen has indicating lines for 6 x 9 and 6 x 7 formats, it can be used as a focusing screen for composing with the roll film holder.

The hood can be separated from the focusing screen panel, by sliding the locking slides on both upper and lower edges.

Optical Viewfinder Model P

for 75mm, 100mm, and 127mm Lenses

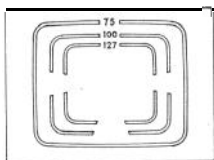

This optical viewfinder is especially designed for 75mm, 100mm and 127mm lenses to permit observing an accurate field of view when taking pictures with the Polaroid Land film pack; series 100 or 660 (3¼ x 4¼ inch).

By attaching the viewfinder to the accessory shoe, and looking through the viewfinder eyepiece, the field of view corresponding to the lens used can be determined.

To compensate for parallax, turn the knob on the back of the viewfinder, and set the focused distance to subject.

Format gauge

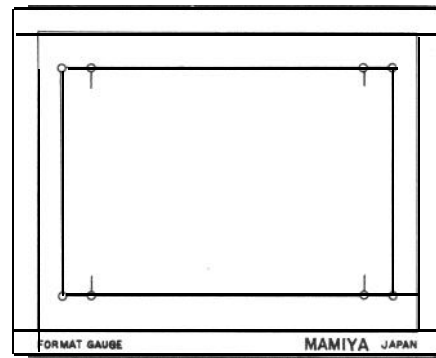

As a preparatory test when taking an important photograph, make a trial exposure with the Polaroid film pack to confirm lighting and composition of the actual object; then photograph the final picture on roll film and so on.

Employing this procedure, unexpected failures can be prevented.

In these cases, when placing this format gauge on the photographed subject, composition when photographing with a 6x9 format or 6 x 7 format can be ascertained in advance.

Since four corners of the outline indicating the respective size are perforated, the picture can be cut and checked after being marked through these holes.

Focusing Screen Holder

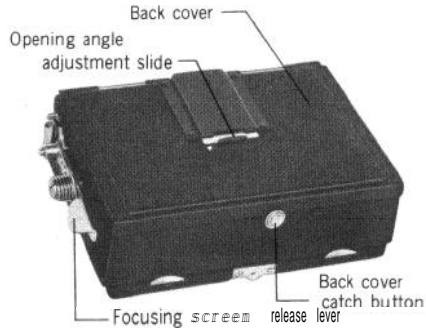

Immediately after focusing with the focusing screen, a cut film/plate holder can be inserted from one side of the focusing screen holder.

How to Open the Back Cover

By moving the back cover catch button at the bottom of the back cover in the direction of the arrow, the back cover will open. With the opening angle adjustment slide kept UP, the back cover will open horizontally; and with the opening angle adjustment slide kept DOWN, the cover will open upward.

Focusing



To focus with the ground glass image, keep the shutter open and the lens at its fullest aperture, focusing by rotating the focusing ring.

(When keeping the shutter open, follow the instructions on Page 16.)

Depth of field can be observed on the ground glass screen through stopping down the diaphragm by turning the aperture control lever.

Full size of the focusing ground glass is for 6 x 9cm format, the light vertical lines indicating the 6 x 7cm format.

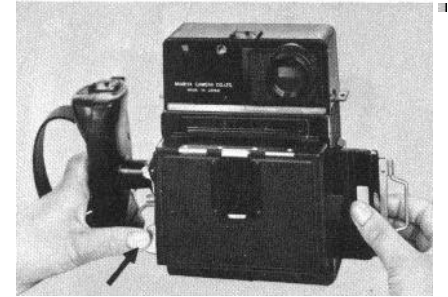

After focusing, press the focusing screen release lever to permit the screen to retract, and insert the cut film/plate holder from one side of the focusing screen holder

To remove the film holder, press the focusing screen release lever with your left hand, hold the film holder and draw it out by pulling it toward you.

Be sure to close the shutter before attaching the film holder. Pull out the dark slide before photographing. Insert the dark slide before removing the film holder.

Right-angle and Magnifying Focusing Backs

Right-angle focusing back

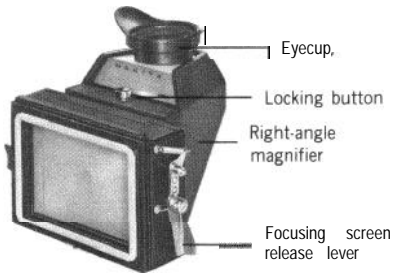

This device enables observing the image on the ground glass from the right-angle direction against the optical axis. The right-angle magnifier can be very simply turned upward or sideward, facilitating focusing from any camera angle.

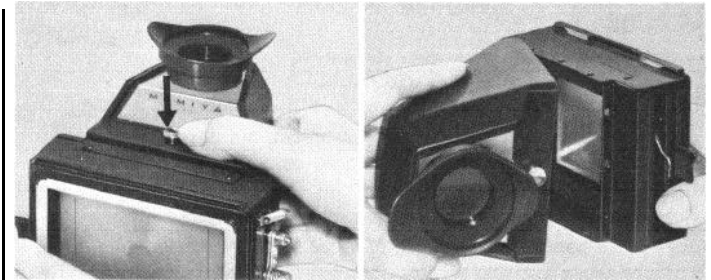

Magnifying focusing back

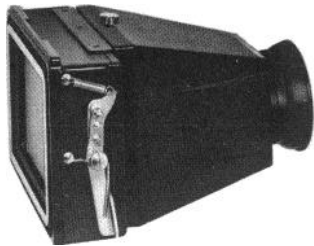

This back is provided with an eye-level, totally enclosed box instead of the right-angle magnifier of the right-angle focusing back. Precise focusing is possible by directly observing the image on the ground glass focusing screen through the eyepiece magnifier.

Since a Fresnel lens is used on both focusing backs, the entire ground glass is very bright, and focusing can be easily accomplished because extraneous light is blocked out. The ground glass has light lines which indicate a 6 x 7 format.

After focusing, insert a cut film/plate holder as well as the focusing screen holder for photographing.

Attaching and Detaching the Right-angle Magnifier

The right-angle magnifier can be removed by swinging it around the bottom of the housing while depressing the button of the right-angle magnifier.

To attach the right-angle magnifier, match the projections at the bottom of the magnifier to the holes of the holder, and press in the upper part. When attaching the magnifier, the button does not need to be pressed.

The right-angle magnifier can be attached for up, down, right, and left directions. Merely attach it in the direction necessary for the camera angle employed.

When looking from above or below, the image assumes the correct right-side-up position, but the right and left will be reversed. When looking from the side, right and left are correct but the image will be upside down.

Composing the Picture by Ground Glass Focusing Screen for Cut Film

When dry plates or $2\frac{1}{2} \times 3\frac{1}{2}$ inch (6.5 x 9 cm) cut films are used, the actual picture format is exactly the same as seen on the focusing screen.

When "one-quarter size" cut films or $2\frac{1}{4} \times 3\frac{1}{4}$ inch cut films are used, since the actual picture size of these films is a little smaller than the ground glass focusing screen, compose the picture within the frame of the broken lines as shown in the drawings.

For "one-quarter size" cut film taken from $4\frac{3}{4} \times 6\frac{1}{2}$ inch
(12 x 16.5cm) cut film;

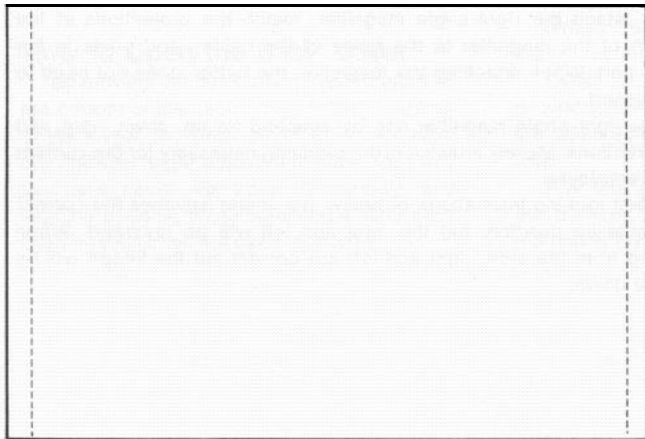

For $2\frac{1}{4} \times 3\frac{1}{4}$ inch cut film;

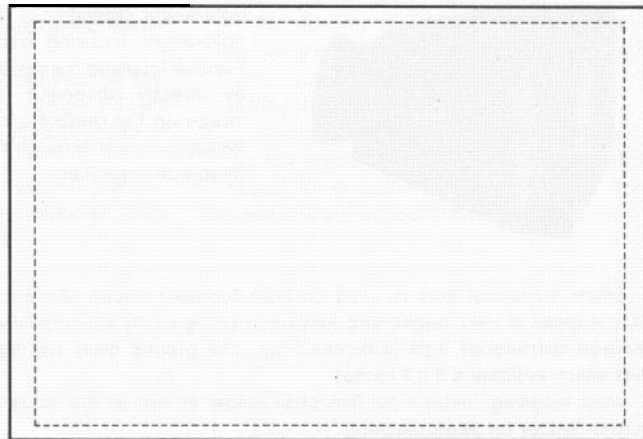

Cut Film/Plate Holder (Type J)

When Using a Dry Plate $2\frac{1}{2} \times 3\frac{1}{2}$ inch (6.5 x 9 cm) :

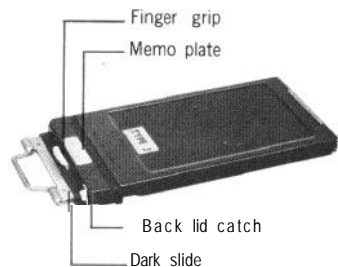

Open the Back Lid:

By pulling out the back lid catch, the back lid can be swung open by applying finger pressure to the finger grip.

Memo plate:

Use the memo plate for recording on the holder your file number, the film type, and so on. Correct recorded letters or figures by rubbing the plate with a finger tip, soft cloth, or tissue.

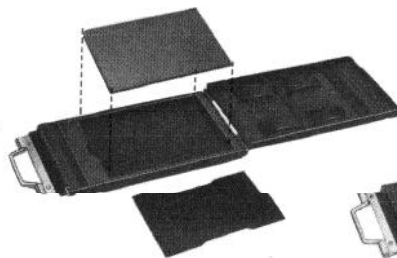

Remove the film sheath from the holder, insert the dry plate with the emulsion side facing the dark slide, close the back lid, and push it back to its original position. In this case, the film sheath is not used.

When Using a Cut Film $2\frac{1}{2} \times 3\frac{1}{2}$ inch (6.5 x 9cm):

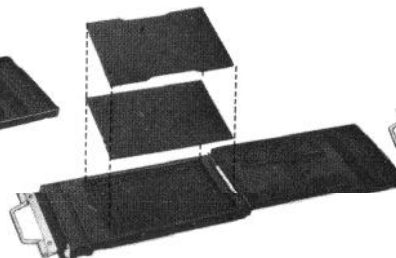

Remove the film sheath from the holder, place the cut film with its emulsion side facing the dark slide, then place the film sheath with the film catch side up, and close the back lid. Instead of the film sheath, a discarded dry plate may be used

When Using a Cut Film Taken by Cutting a $4\frac{1}{4} \times 6\frac{1}{2}$ inch Cut Film into Four One-quarter Sizes:

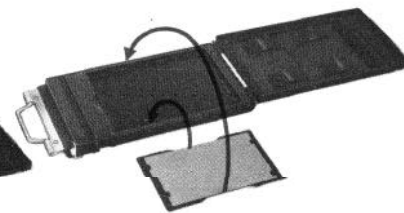

Insert the cut film in the film sheath with its emulsion side up, placing the sheath in the holder.

When a color film is cut, sometimes the film is not developed at a developing laboratory. For color photography, therefore, use factory-cut $2\frac{1}{2} \times 3\frac{1}{2}$ inch (6.5 x 9cm) color film.

Cut Film/Plate Holder (Type A)

When Using a Dry Plate $2\frac{1}{2} \times 3\frac{1}{2}$ inch (6.5 x 9cm):

When Using a Cut Film $2\frac{1}{4} \times 3\frac{3}{4}$ inch:

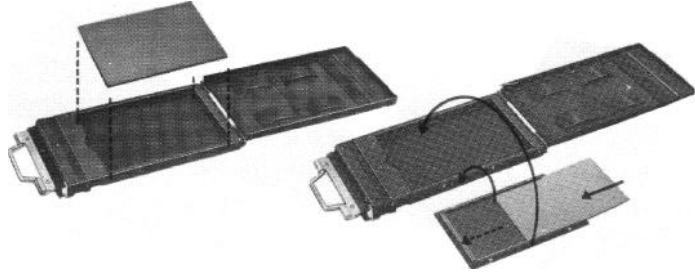

Remove the film sheath from the holder, insert the dry plate with the emulsion side facing the dark slide, close the back lid, and push it back to its original position. In this case, the film sheath is not used.

Use the cut film/plate holder (type A). Insert a film in the film sheath, place it in the holder, and close the back lid. This film sheath is exclusive for type A; do not use it with a type J holder.

Extension Rings



Use a set of five extension rings in various combinations between the lens-shutter assembly and the camera body for close-up photography.

The values in the table represent those when the five extension rings are attached and the lens distance scale is set at the closest distance.

The lens-to-subject distance represents the distance of the subject from the front extremity of the lens barrel.

Subject coverage is the area of the subject registered on the focusing screen ($2\frac{1}{4} \times 3\frac{5}{16}$ in 57 x 84mm).

Precaution

When using many extension rings for photographing in the 6 x 9cm format, certain lenses may produce pictures with darker corners. By stopping down the aperture while looking into the focusing screen, how much darker the corners appear can be observed.

The 75mm f/5.6 and 250mm f/5 lenses cannot be mounted with extension rings.

Maximum Close-up Photographing Table

Lens	Lens-to-subject Distance	Magnification	Subject Coverage		Exposure Factor
			6 x 9	6 x 7	
50mm f/6.3	$1\frac{3}{8}"$ (47.9mm)	2.04	$1\frac{5}{64}" \times 1\frac{5}{8}"$ 28 x 41mm	$1\frac{5}{64}" \times 1\frac{3}{64}"$ 28 x 35mm	9.2
100mm f/2.8	$5\frac{1}{8}"$ (130mm)	1.13	$2" \times 2\frac{9}{64}"$ 51 x 75mm	$2" \times 2\frac{1}{32}"$ 51 x 61mm	4.6
100mm f/3.5	$6\frac{3}{64}"$ (167mm)	1.14	$1\frac{31}{32}" \times 2\frac{1}{8}"$ 50 x 73mm	$1\frac{31}{32}" \times 2\frac{3}{64}"$ 50 x 60mm	4.6
127mm f/4.7	$10\frac{5}{64}"$ (256mm)	0.90	$2\frac{31}{64}" \times 3\frac{5}{8}"$ 63 x 92mm	$2\frac{31}{64}" \times 3"$ 63 x 76mm	3.6
150mm f/5.6	$1\frac{19}{32}"$ (320mm)	0.77	$2\frac{7}{8}" \times 4\frac{1}{4}"$ 73 x 108mm	$2\frac{7}{8}" \times 3\frac{1}{64}"$ 73 x 83mm	3.1

Spacer Set

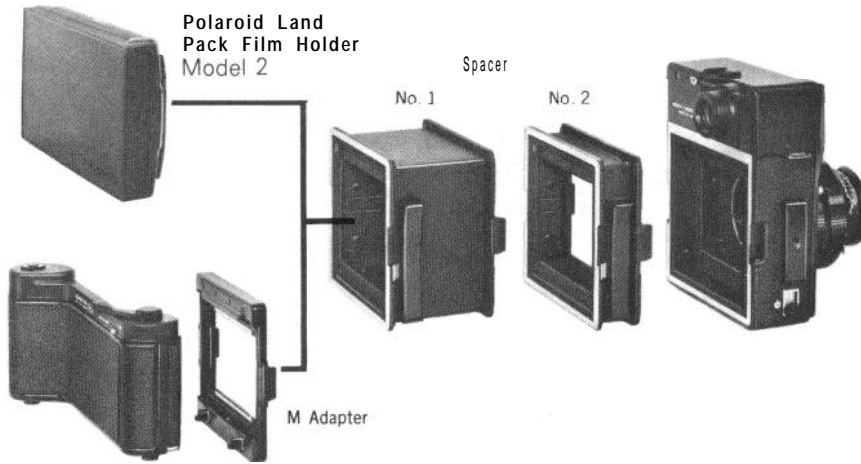

Indication sheet for subject coverage
for 6 x 9 and 6 x 7 cm format

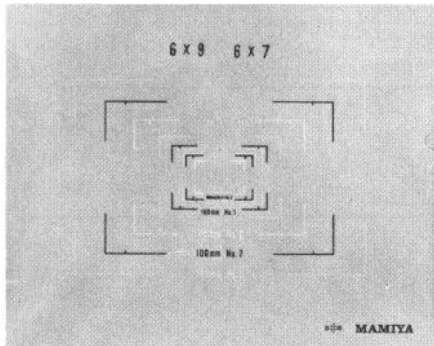

for 3 1/4 x 4 1/4 inch format

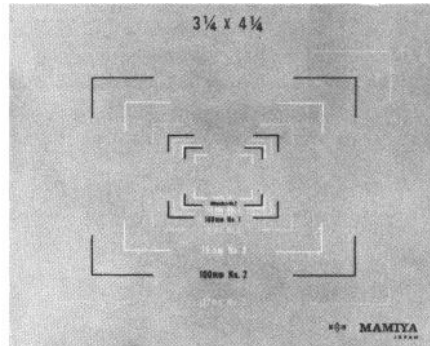

A spacer is a device for close-up photography by extending the camera back by installing a spacer between the camera back and the film holder.

Since two types (No. 1 spacer and No. 2 spacer) are combined as one set, the photographing range can be varied by changing the combination or the lens to be used.

Extreme close-up photography can be achieved by combining with the extension rings.

The Polaroid Land pack film holder can be directly installed on the spacer. When using an M-adapter or G-adapter, photography through all holders installable on these adapters can be achieved.

Indication Sheet for Subject Coverage

On the vinyl sheet in the spacer set, subject coverages varying according to the combination of lenses (75mm f/5.6, 100mm f/3.5, and 127mm f/4.7) and spacers are indicated through color identification.

Close-up Photographing Table

The left-side values in each column of the close-up photographing table indicate values when setting the lens distance scale to ∞ (infinity). The right-side values indicate when extending the lens to the nearest close-up distance scale.

The lens-to-subject distance indicates the distance from the front edge of the lens barrel to the subject.

Magnification indicates the ratio of image and the subject size

Close-up Photographing Table for 75 mm f/5.6 Lens

Combination	Lens-to-subject distance	Magnification	Subject coverage			Exposure factor
			$3\frac{1}{4} \times 4\frac{1}{4}$	6×9	6×7	
No. 2	$8\frac{3}{16}'' \sim 6\frac{3}{32}''$ 208~177mm	0.42~0.51	$6\frac{1}{16}'' \times 8\frac{3}{8}'' \sim 5\frac{1}{32}'' \times 7\frac{9}{32}''$ (173×226)~(142×185)mm	$5\frac{1}{4}'' \times 7\frac{23}{32}'' \sim 4\frac{9}{32}'' \times 6\frac{11}{32}''$ (133×196)~(109×161)mm	$5\frac{1}{4}'' \times 6\frac{3}{8}'' \sim 4\frac{9}{32}'' \times 5\frac{1}{4}''$ (133×162)~(109×133)mm	2.0~2.3
No. 1	$4\frac{3}{16}'' \sim 3\frac{1}{16}''$ 106~100mm	1.00~1.09	$2\frac{7}{8}'' \times 3\frac{3}{4}'' \sim 2\frac{5}{8}'' \times 3\frac{3}{16}''$ (73×95)~(67×87)mm	$2\frac{3}{32}'' \times 3\frac{9}{32}'' \sim 2\frac{1}{16}'' \times 3''$ (56×83)~(52×76)mm	$2\frac{7}{32}'' \times 2\frac{1}{16}'' \sim 2\frac{1}{16}'' \times 2\frac{1}{2}''$ (56×68)~(52×63)mm	4.0~4.4
No. 1 + No. 2	$3\frac{5}{16}'' \sim 3\frac{3}{16}''$ 84~81mm	1.42~1.51	$2'' \times 2\frac{5}{8}'' \sim 1\frac{7}{8}'' \times 2\frac{1}{2}''$ (51×67)~(48×63)mm	$1\frac{1}{16}'' \times 2\frac{9}{32}'' \sim 1\frac{1}{32}'' \times 2\frac{9}{32}''$ (40×58)~(37×55)mm	$1\frac{1}{16}'' \times 1\frac{7}{8}'' \sim 1\frac{1}{32}'' \times 1\frac{3}{32}''$ (40×48)~(37×45)mm	5.9~6.3

Close-up Photographing Table for 100 mm f/3.5 Lens (Lens is nonretracted condition)

Combination	Lens-to-subject distance	Magnification	Subject coverage			Exposure factor
			$3\frac{1}{4} \times 4\frac{1}{4}$	6×9	6×7	
No. 2	$1' 3\frac{1}{2}'' \sim 1'$ 393~304mm	0.32~0.44	$9\frac{1}{8}'' \times 11\frac{1}{8}'' \sim 8\frac{1}{32}'' \times 8\frac{1}{32}''$ (230×300)~(164×215)mm	$6\frac{3}{32}'' \times 10\frac{9}{32}'' \sim 5'' \times 7\frac{3}{8}''$ (177×261)~(127×187)mm	$6\frac{3}{32}'' \times 8\frac{1}{2}'' \sim 5'' \times 6\frac{1}{16}''$ (177×216)~(127×154)mm	1.7~2.1
No. 1	$8\frac{11}{32}'' \sim 7\frac{9}{16}''$ 212~192mm	0.75~0.88	$3\frac{1}{16}'' \times 5'' \sim 3\frac{3}{32}'' \times 4\frac{3}{32}''$ (97×127)~(83×109)mm	$2\frac{1}{16}'' \times 4\frac{1}{32}'' \sim 2\frac{1}{32}'' \times 3\frac{3}{4}''$ (75×110)~(64×95)mm	$2\frac{1}{16}'' \times 3\frac{1}{32}'' \sim 2\frac{1}{32}'' \times 3\frac{1}{16}''$ (75×91)~(64×78)mm	3.1~3.5
No. 1 + No. 2	$6\frac{23}{32}'' \sim 6\frac{7}{16}''$ 172~163mm	1.07~1.20	$2\frac{1}{16}'' \times 3\frac{1}{2}'' \sim 2\frac{1}{32}'' \times 3\frac{5}{32}''$ (68×89)~(61×80)mm	$2\frac{3}{32}'' \times 3\frac{1}{16}'' \sim 1\frac{27}{32}'' \times 2\frac{23}{32}''$ (53×78)~(47×69)mm	$2\frac{3}{32}'' \times 2\frac{1}{32}'' \sim 1\frac{27}{32}'' \times 2\frac{1}{4}''$ (53×64)~(47×57)mm	4.3~4.8

Close-up Photographing Table for 127 mm f/4.7 Lens

Combination	Lens-to-subject distance	Magnification	Subject coverage			Exposure factor
			$3\frac{1}{4} \times 4\frac{1}{4}$	6×9	6×7	
No. 2	$2' \sim 1' 6\frac{7}{32}''$ 610~463mm	0.25~0.35	$11\frac{1}{2}'' \times 1' 3'' \sim 8\frac{3}{32}'' \times 10\frac{21}{32}''$ (292×381)~(207×271)mm	$8\frac{7}{8}'' \times 1' 1\frac{1}{16}'' \sim 6\frac{3}{16}'' \times 9\frac{3}{32}''$ (225×332)~(160×236)mm	$8\frac{7}{8}'' \times 10\frac{3}{32}'' \sim 6\frac{3}{16}'' \times 7\frac{3}{8}''$ (225×274)~(160×194)mm	1.6~1.8
No. 1	$1' 1\frac{1}{32}'' \sim 11\frac{1}{4}''$ 318~286mm	0.59~0.69	$4\frac{3}{32}'' \times 6\frac{1}{32}'' \sim 4\frac{1}{8}'' \times 5\frac{1}{32}''$ (123×161)~(105×137)mm	$3\frac{3}{4}'' \times 5\frac{1}{2}'' \sim 3\frac{3}{16}'' \times 4\frac{23}{32}''$ (95×140)~(81×120)mm	$3\frac{3}{4}'' \times 4\frac{9}{16}'' \sim 3\frac{3}{16}'' \times 3\frac{23}{32}''$ (95×116)~(81×99)mm	2.5~2.9
No. 1 + No. 2	$10' \sim 9\frac{3}{8}''$ 254~238mm	0.84~0.94	$3\frac{1}{16}'' \times 4\frac{1}{16}'' \sim 3\frac{1}{32}'' \times 3\frac{1}{32}''$ (87×113)~(77×101)mm	$2\frac{3}{8}'' \times 3\frac{27}{32}'' \sim 2\frac{3}{16}'' \times 3\frac{1}{32}''$ (67×99)~(60×88)mm	$2\frac{3}{8}'' \times 3\frac{3}{16}'' \sim 2\frac{3}{8}'' \times 2\frac{1}{8}''$ (67×81)~(60×73)mm	3.4~3.8

Life-size Photocopying Set

The life-size photocopying set is used for actual size photography by using the 75 mm f/5.6 or 100 mm f/3.5 lens and the spacers.

A sheet for determining the position of subject to be copied and a nonglare glass which prevents reflection are included.

When using the 75 mm f/5.6 lens: **When using the 100 mm f/3.5 lens:**

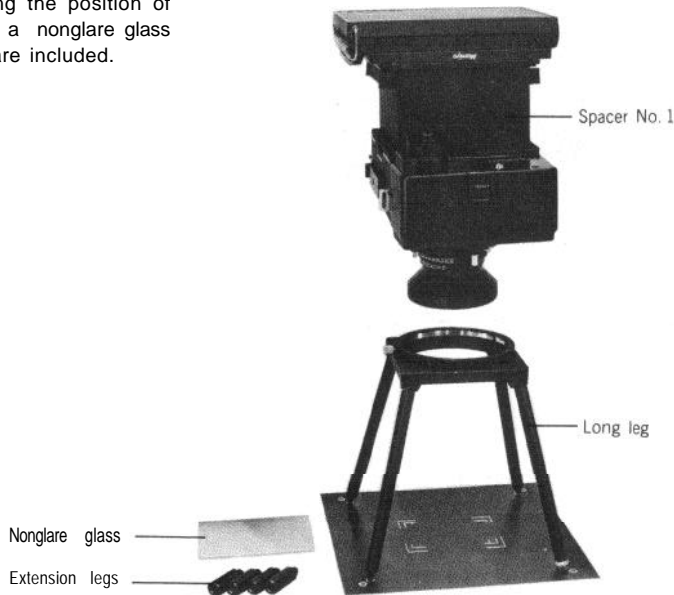

Use spacer No. 1.
Set lens distance scale to infinity (∞)
Install only the four long legs to the photocopying stand.

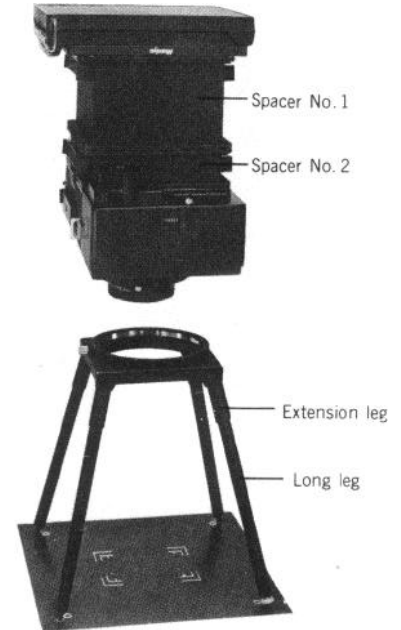

Use spacers No. 1 and No. 2.
Retract the lens and set the distance scale to 3m.
Install long legs and extension legs on the photocopying stand.

Tetrphoto Adapter

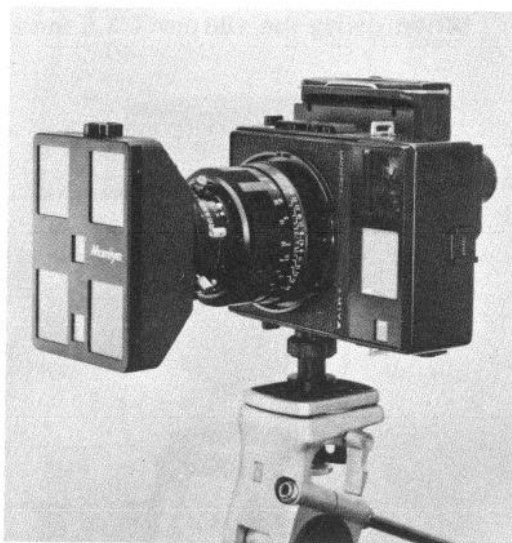

Polaroid Land film pack 100 or 660 series is used for the tetrphoto adapter, whereby quadruple photos can be obtained by a single exposure. Ideal for taking photos for driver's licenses and identification cards.

Lens and Accessories to be used

127mm f/4.7 lens

Polaroid Land pack film holder

Tripod adapter (for vertical format)

Photographing

Set the height (optical axis) of the camera on which the tetrphoto adapter is installed to the height of eyes of the subject to be photographed, placing the camera in front of the subject; then adjust the distance.

After confirming whether or not the adapter is inclined, position the center of the subject's face in the center of the adapter finder field of view.

As shown in the sketch, prepare a white background for use only as the photographing range, and use back which reflects negligible light from other portions and on the floor.

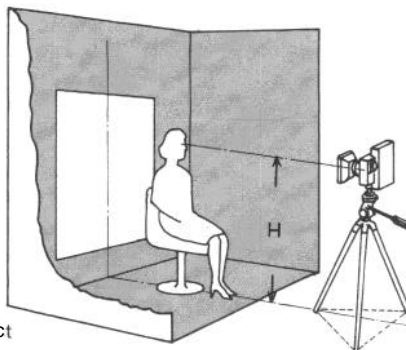

H: Height of eyes of the subject

Accessories for the Viewfinder

Sports Finder

For both Mamiya Universal and the Mamiya Press Super 23, this is available in 6x9 and 6x7 formats, both with wire frames for 100 mm and 150 mm lenses.

Really an indispensable accessory for photographing quick-moving subjects.

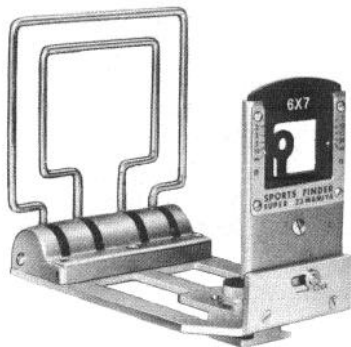
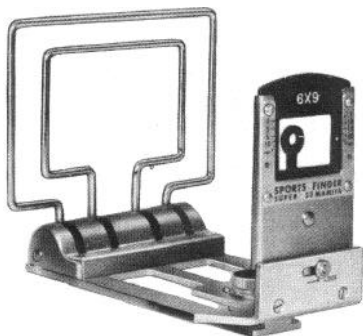

Eyecup



Maintains the correct eye position and Prevents extraneous light from entering the viewfinder from the back when looking into the viewfinder. Attach this to the eyepiece.

Eye-correction Lens

The finder image is adjusted for those people with normal eyesight. Nearsighted or farsighted people without glasses, or those with improper glasses, will have difficulty looking into the image. Use this lens in such cases.

There are eight diopter lenses available (+3, +2, +1, -0.5, -1, -2, -3, and -4).

To attach the lens to the eyepiece, turn the ring on the eyepiece counterclockwise and remove it, insert the lens, and screw the ring back in as it was.

Extension Eyepiece



An Extension Eyepiece (magnification of 0.75X) is available for use with the 70mm Film Holder. Even with the holder attached to the Mamiya Universal camera, the entire field of the viewfinder is clearly visible when the Extension Eyepiece is used.

To attach the Extension Eyepiece to the camera, merely unscrew the Eyepiece Retainer Ring of the camera by turning counterclockwise, and then screw in the Extension Eyepiece in its place.

In addition to being a necessary accessory for the 70mm Film Holder, the Extension Eyepiece will also prove to be a valuable aid when used with other Mamiya Press Film Holders.

Grip and Tripod Adapter

Rotating Grip

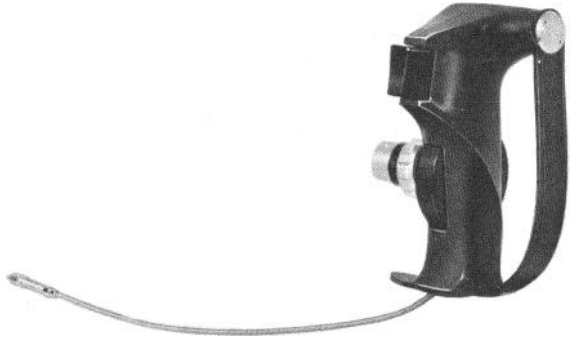

This is a unique grip whose angle is freely adjusted according to the photographing posture.

This grip rotates approximately 180°, centering the installation point to the camera; however, when grasping the center belt of the grip, the grip is secured at an optional angle.

Rotating Adapter



This is a convenient universal head which can be freely changed over from a vertical photographing position to a horizontal photographing position (or vice versa) by revolving the camera installed on the tripod, centering the camera optical axis.

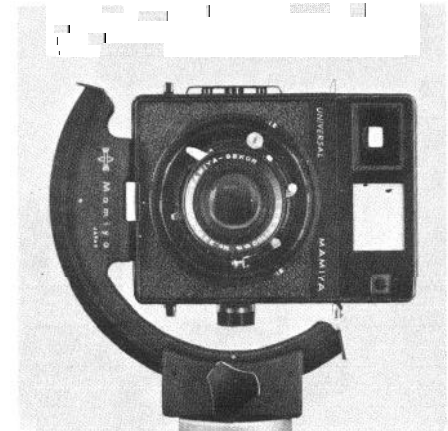
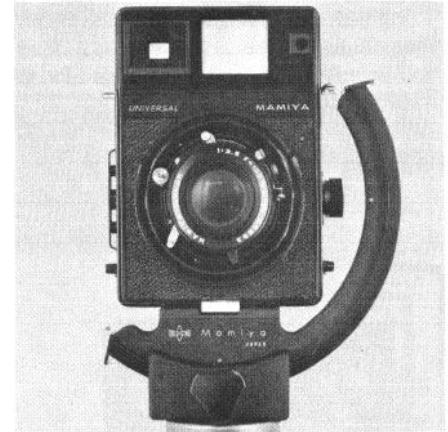

Tripod Adapter (For Vertical Format)

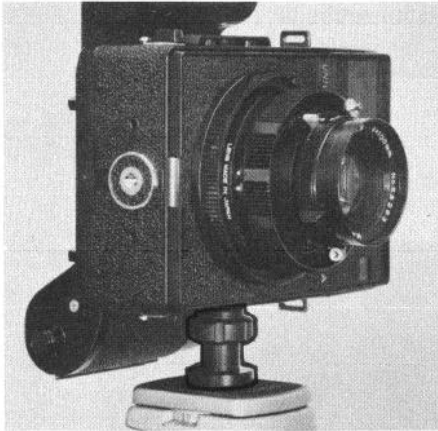

For photographing vertical format pictures on a tripod, remove the hand grip from the camera body and attach this tripod adapter to the socket.



Quick-shoe Model 2

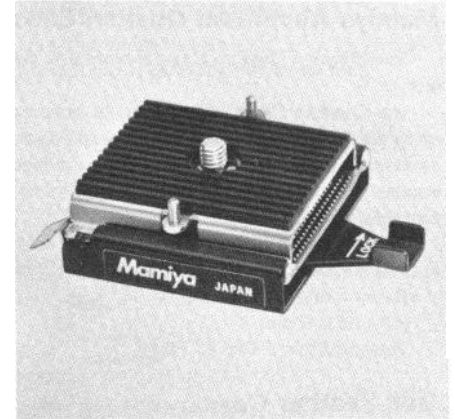

A two piece set in which one piece is attached to the camera and the other to the tripod. When this is done, the camera can instantly be mounted to, or removed from, a tripod without the need to fumble with screws.

Case

Mamiya Aluminum Custom Case

The Mamiya Custom Case is a smartly portable, luggage-type aluminum case.

The Custom Case is designed to accommodate and to easily hand-carry normally required interchangeable lenses and accessories as well as standard equipment. By changing the inserts, the Custom Case conveniently accommodates the Mamiya Press, Mamiya C, or Mamiya RB and related equipment.

The interchangeable inserts, made of sponge rubber, provide effective shock absorption and sufficient protection of the equipment.

Dimensions(outer): 18 $\frac{1}{2}$ " \times 13 $\frac{1}{2}$ " \times 6 $\frac{1}{4}$ "

(47 x 35 x 17cm)

Weight: 8lbs, 2 $\frac{1}{2}$ oz.,(3.7kg).

Soft Leather Case

A flexible and convenient soft case for lens protection and carrying, Can be used for accommodating one of lenses from 50mm to 150mm, or extension rings or accessories, and so on.

